



**LEGENDA EM PLANTA:**

-  CURVAS DE NÍVEL INTERMEDIÁRIA ( A CADA 0,5m)
-  CURVAS DE NÍVEL MESTRA ( A CADA 5m)
-  PARTIDO URBANÍSTICO
-  ÁREAS DE AFLORAMENTO DO LENÇOL FREÁTICO

A2

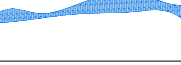
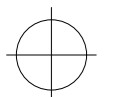
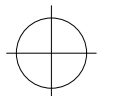

**CONFIGURAÇÃO DE PENAS**

COR	ESPESSURA
VERMELHO	0,10
AMARELO	0,20
VERDE	0,30
CYAN	0,40
AZUL	0,60
MAGENTA	0,80
BRANCO	1,20
05	0,05
10	0,10
12	0,40
17	0,10
20	0,25
26	0,25
30	0,20
33	0,20
35	0,10
40	0,25
44	0,15
52	0,25
65	0,10
102	0,10
130	0,50
140	0,40
160	0,25
170	0,25
174	0,15
200	0,20
220	0,10

**COR:**



VERMELHO	07
AMARELO	07
VERDE	07
CYAN	07
AZUL	07
MAGENTA	07
BRANCO	07
200	07
DEMAS	COR PRÓPRIA

**TIPOS DE LINHA**

VERDE	ISO DASH SPACE
DEMAS	CONTINUOUS



**LEGENDA EM PLANTA:**

-  PARTIDO URBANÍSTICO
-  TUBO PEAD CORRUGADO PERFURADO - Ø 150 mm
-  CAIXAS DE PASSAGEM

A2

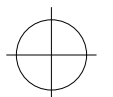
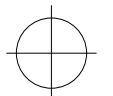

**CONFIGURAÇÃO DE PENAS**

COR	ESPESSURA
VERMELHO	0.10
AMARELO	0.20
VERDE	0.30
CYAN	0.40
AZUL	0.60
MAGENTA	0.80
BRANCO	1.20
05	0.05
10	0.10
12	0.12
17	0.17
20	0.20
25	0.25
30	0.30
35	0.35
40	0.40
44	0.44
45	0.45
50	0.50
60	0.60
100	1.00
150	1.50
200	2.00
250	2.50
300	3.00
350	3.50
400	4.00
450	4.50
500	5.00

COR	TIPO
VERMELHO	07
AMARELO	07
VERDE	07
CYAN	07
AZUL	07
MAGENTA	07
BRANCO	07
200	07
DESMAS	COR PRÓPRIA



  

TIPOS DE LINHA	ISO DASH SPACE
VERDE	CONTÍNUO
DESMAS	CONTÍNUO

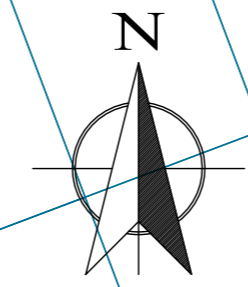
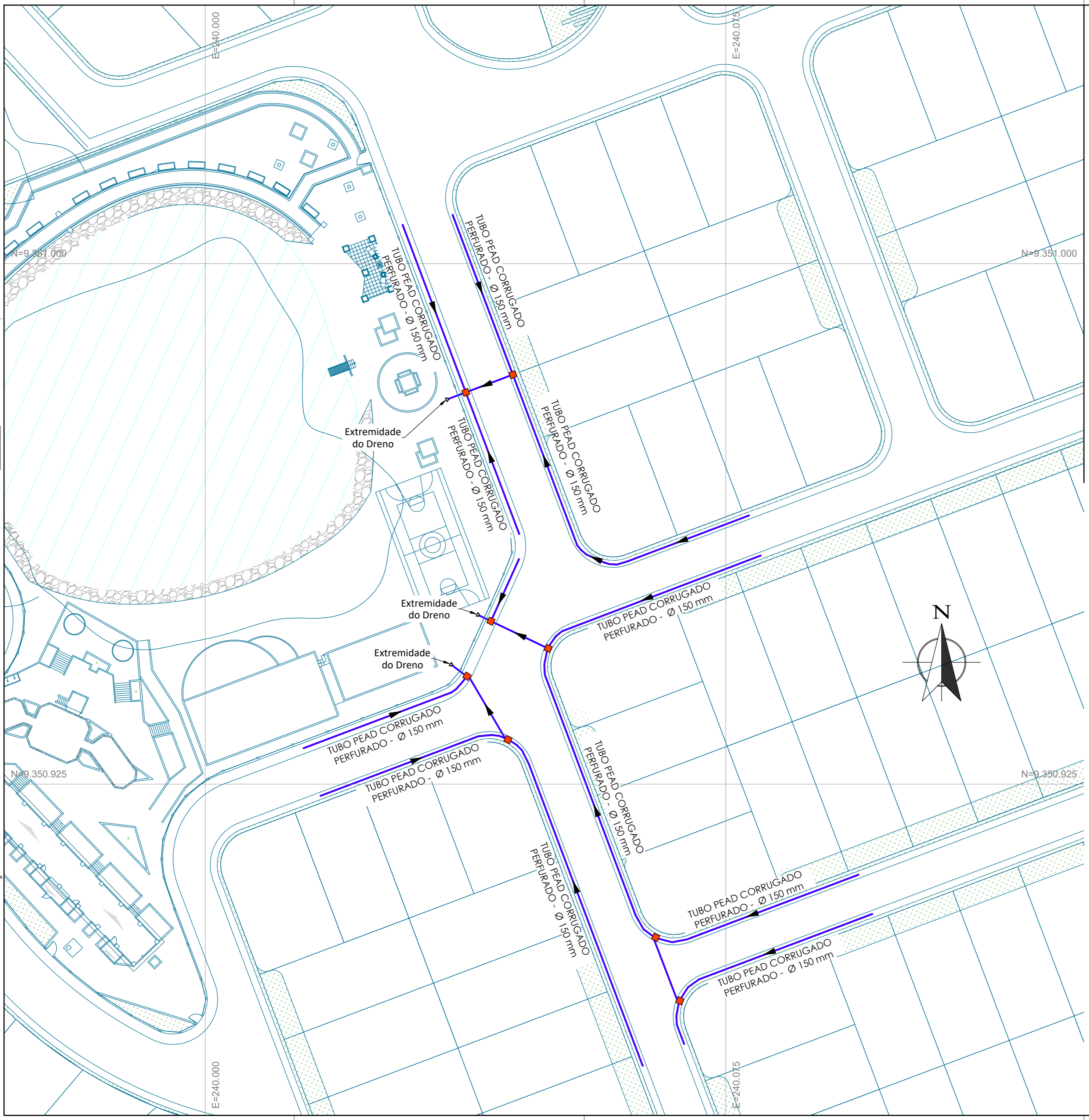



LEGENDA EM PLANTA:

-  PARTIDO URBANÍSTICO
-  REEXECUÇÃO DO PAVIMENTO EM TSD (TRATAMENTO SUPERFICIAL DUPLO)

A2

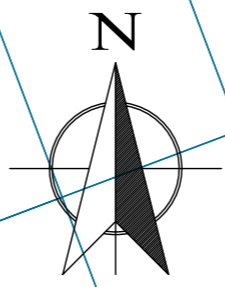

CONFIGURAÇÃO DE PENAS

COR	ESPESSURA
VERMELHO	0.10
AMARELO	0.20
VERDE	0.30
CYAN	0.40
AZUL	0.60
MAGENTA	0.80
BRANCO	1.20
05	0.05
10	0.10
12	0.40
17	0.10
20	0.25
25	0.25
30	0.20
32	0.20
33	0.10
40	0.20
44	0.15
45	0.20
50	0.10
60	0.10
100	0.40
130	0.50
140	0.40
160	0.20
170	0.10
174	0.10
200	0.20
220	0.10

COR:

VERMELHO	07
AMARELO	07
VERDE	07
CYAN	07
AZUL	07
MAGENTA	07
BRANCO	07
200	07
DEMAS	COR PRÓPRIA

TIPOS DE LINHA

VERDE	ISO DASH SPACE
DEMAS	CONTINUOUS

A3

DETALHES DO DRENO  
ESCALA: 1/20

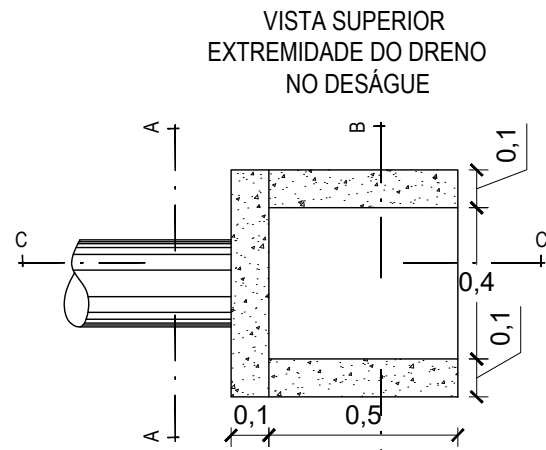
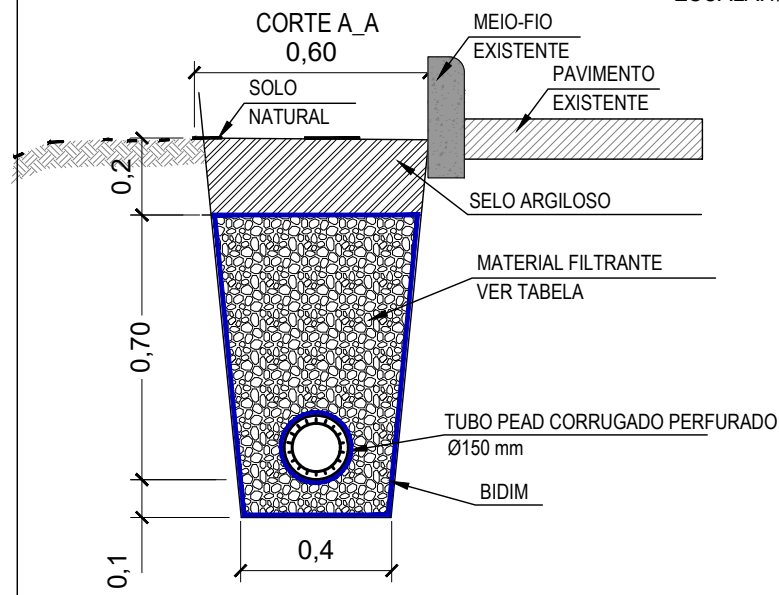

CORTE B\_B  
EXTREMIDADE DO DRENO  
NO DESÁGUE

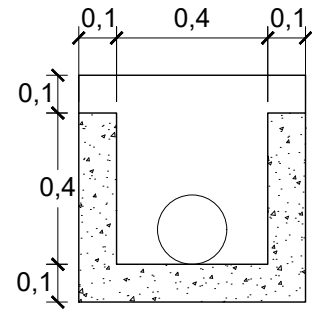

GRANULOMETRIA DO MATERIAL FILTRANTE	
PENEIRAS (mm)	%, EM PESO, PASSANDO
9,5	100
4,8	95 - 100
1,2	45 - 80
0,3	10 - 30
0,15	2 - 10

CORTE C\_C  
EXTREMIDADE DO DRENO  
NO DESÁGUE

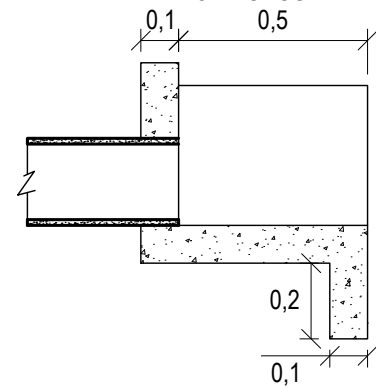

CAIXA DE PASSAGEM  
VISTA SUPERIOR

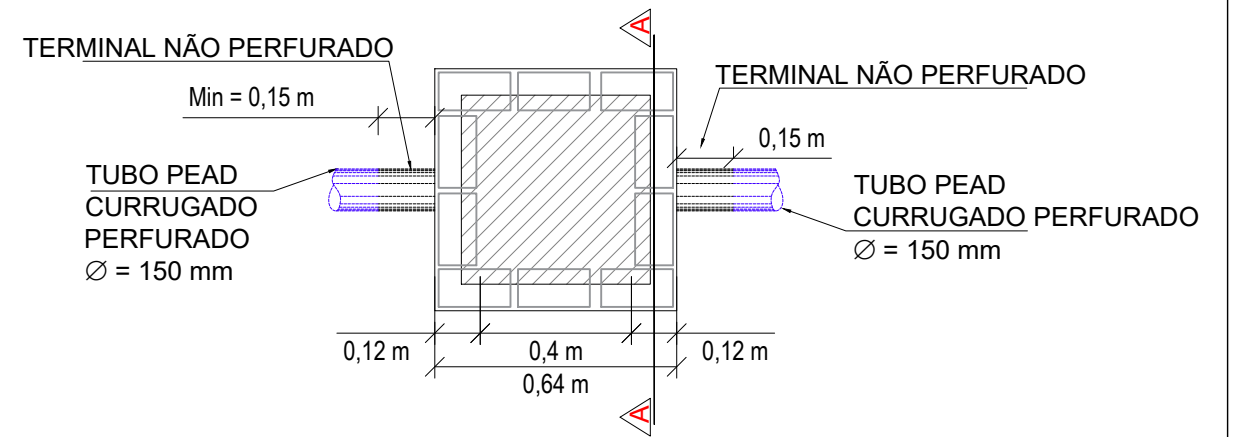

CORTE AA  
ESCALA: 1:20

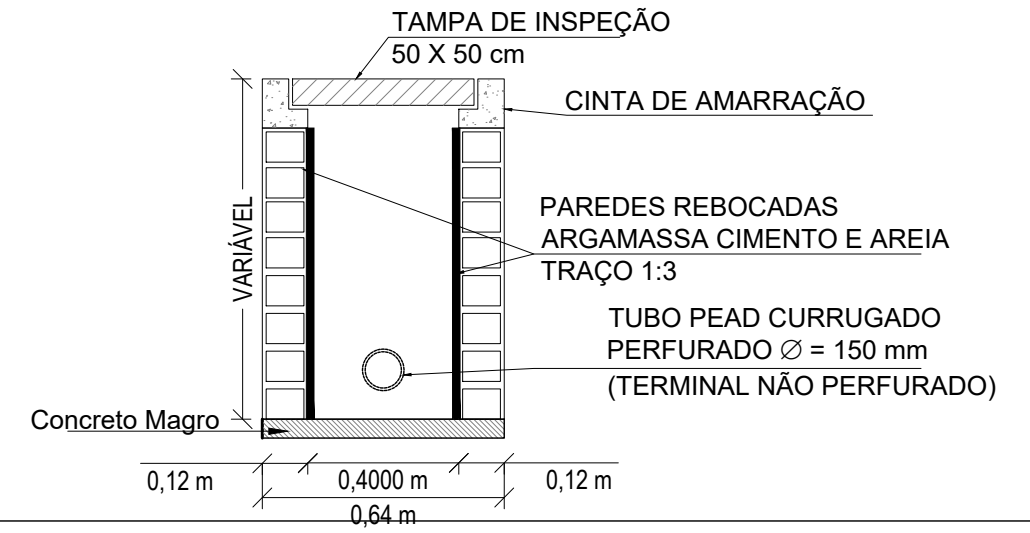

CONFIGURAÇÃO DE PENAS

COR	ESPESSURA
VERMELHO	0,10
AMARELO	0,20
VERDE	0,30
CYAN	0,40
AZUL	0,60
MAGENTA	0,80
BRANCO	1,20
08	0,05
10	0,10
12	0,40
17	0,10

20	
26	
30	
32	
33	
40	
44	
45	
65	
102	
130	
140	
160	
170	
174	
200	
252	
254	

COR:

VERMELHO	
AMARELO	
VERDE	
CYAN	
AZUL	
MAGENTA	
BRANCO	
200	
DEMAIS	COR PRÓPRIA

TIPOS DE LINHA

VERDE	ISO DASH SPACE
DEMAIS	